

# TF300B Trencher

# ASTEC

## ENGINE

Manufacturer ..... Briggs & Stratton  
Model ..... Vanguard  
Type ..... Gasoline  
Cylinders ..... 2 (V-twin)  
Bore/Stroke ..... 2.97" x 2.76"  
(7.5 x 7 cm)  
Displacement ..... 38 in<sup>3</sup> (627 cc)  
Horsepower ..... 18.5 (13.8 kW)  
@ 3100 rpm  
Max. torque ..... 32 lb-ft (43.3 N·m)  
@ 2400 rpm

## DRIVELINE

Hydraulic drive with final drives sealed and enclosed in oil. Infinitely variable speed. Direct-drive clutches and multi-disc steering brakes. Two speed ranges, transport and working. Hydraulic fixed displacement pump with variable flow from valve to fixed displacement motor on final drive.

### Travel/work speeds

Transport ..... 1.8 mph (2.2 km/h)  
Working ..... 0 to 30 ft./min.  
(9.1 m/min.)

## OPERATOR ENVIRONMENT

Electric start and shut-down  
Hand throttle and choke  
Single lever forward/reverse  
Dual steering and brake levers  
Variable speed creep control  
Trencher chain clutch lever  
Low noise, low vibration engine  
Optional backfill blade controls  
Operator noise level ..... 86.7 dB

## UNDERCARRIAGE

High-flotation tracks available in cleat-type steel or rubber tracks  
Track rollers ..... Sealed  
Track ground area ..... 730 in<sup>2</sup>  
(4710 cm<sup>2</sup>)  
Ground pressure  
w/backfill blade ..... 3.1 psi  
w/o backfill blade ..... 2.6 psi

## HYDRAULIC SYSTEM

Ground drive pump  
@ 3100 rpm ..... 11.3 gpm  
(42.7 l/min)  
Relief valve setting ..... 2550 psi  
(17 580 kPa)  
Boom anti-drift valve ..... Standard  
Filtration ..... 10 micron spin-on

## ELECTRICAL SYSTEM

Battery ..... 12 volts, 340 CCA  
Alternator ..... 12 volt, 16 amp  
Gauges  
Ammeter  
Digital tachometer  
Digital hourmeter  
Low oil shutdown system (engine)  
Neutral start safety logic  
Seat interlock system

## SERVICE CAPACITIES

Fuel tank ..... 5.5 gal (20.8 L)  
Engine oil  
w/ filter change ..... 1.75 qt (1.7 L)  
Hydraulic reservoir ... 7.0 gal (26.5 L)  
Transmission ..... 1.0 qt (0.95 L)  
Satellite gearbox ..... 0.25 qt (0.25 L)

## TRENCHER

Boom mounting options  
Centerline for (4"-12") cut width  
Offset 2" for (14"-16") cut width  
Flush digger  
Centerline of flush digging attachment to outside edge of track ..... 5" (12.7 cm)  
Chainline speed ..... 338 ft/min.  
(103 m/min.)  
Spoil removal ..... Auger  
Digging depth and width —  
Sprocket boom  
Dig depth ..... to 45" (114 cm)  
Dig width ..... 4-16" (10-40.6 cm)  
Channel boom  
Dig depth ..... to 45" (114 cm)  
Dig width ..... 4-16" (10-40.6 cm)

## BACKFILL BLADE

Angle (left/right) ..... 40° each way  
Dual lever controls  
Blade lift/lower float position

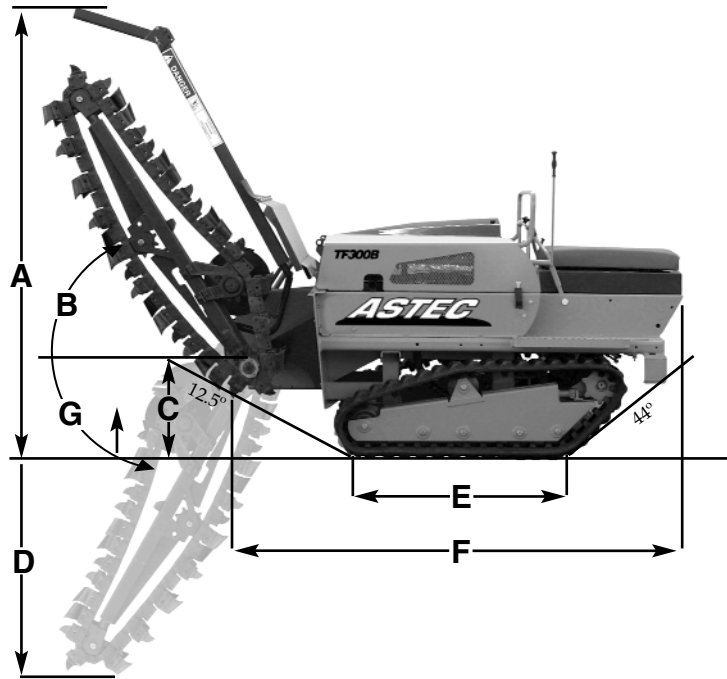

## DIMENSIONS/WEIGHTS

A. Maximum height* - transport.....	77" (195.5 cm)
B. Boom travel - above horizontal.....	Up 70°
C. Trencher shaft height.....	13.7" (34.8 cm)
D. Maximum dig depth.....	45" (114.3 cm)
E. Length of track on ground.....	36.5" (92.7 cm)
F. Length - basic unit w/o blade, boom and chainline.....	85" (215.9 cm)
G. Boom travel - below horizontal.....	Down 60°
Backfill blade height.....	16" (40.8 cm)
Backfill blade width.....	56" (142 cm)
Backfill blade lift above ground.....	10" (25 cm)
Backfill blade depth of cut.....	4" (10 cm)
Overall width - w/o backfill blade.....	41" (104.1 cm)
Overall width - w/ backfill blade straight.....	56" (142 cm)
Length - basic unit w/blade and w/o boom and chainline.....	108" (274.3 cm)
Length - w/ backfill blade and 40" boom, trencher raised.....	137" (348 cm)
Length w/o backfill blade and w/26" boom, trencher raised.....	103" (262 cm)
Weight - w/40" boom and w/o backfill blade.....	1,945 lb (882 kg)
Weight - w/40" boom and backfill blade.....	2,315 lb (1050 kg)
Weight - w/40" boom, backfill blade and ROPS.....	2,450 lb (1111 kg)

\* With ROPS option.

NOTE: All specifications are stated in accordance with SAE Standards or Recommended Practices, where applicable.

IMPORTANT: Astec Underground reserves the right to change these specifications without notice and without incurring any obligation relating to such change. Astec Underground does not warrant the safety or reliability of attachments from other manufacturers.

Visit Astec Underground on the Web at:  
<http://www.astecunderground.com>  
 Printed in U.S.A.

Form No. AT 107 0105

### ASTEC UNDERGROUND CONTACT INFORMATION

9600 CORPORATE PARK DRIVE  
 LOUDON, TN 37774  
 TOLL FREE 800.527.6020  
 PHONE 865.408.2100  
 FAX 865.458.8575

© 2005 ASTEC UNDERGROUND  
 All Rights Reserved.

# ASTEC